

Deluge Valve

**Model: FIS-DVL-FF / FIS-DV-FF /
FIS-DVL-FG / FIS-DV-FG /
FIS-DVL-GG / FIS-DV-GG**

Version 1.02
June 2026 release

Deluge Valve

Model: FIS-DVL-FF/
FIS-DV-FF/FIS-DVL-FG/
FIS-DV-FG/FIS-DVL-GG/
FIS-DV-GG



Product Features

- Valve can be activated remotely
- Remote action control mode: electric or pneumatic
- Connection: Groove*Groove, Flange*Groove, Flange*Flange
- Suitable for horizontal or vertical installation
- FM UL with 300PSI

Technical Features

- Design Standard: ASME B16.42-2016
- Flange Standard: Class 150/300 or DIN2501 PN16/PN25
- Groove Standard: AWWA C606 / ISO 6182
- Working Temperature Range: 4-52°C / 39.2-125.6°F
- Reserved alarm valve system interface: 3/4"NPT
- Available Sizes: 2"-8"
- Maximum Working Pressure: 250PSI or 300PSI (can be chosen)
- Maximum Testing Pressure: 500PSI/600PSI conforms to UL260, FM1011/1012/1013, FM1020

Applications in Fire Protection

It is suitable for automatic sprinkler systems installed in places such as residential houses, hospitals, hotels, shopping malls, factories, airports, casinos, libraries, stadiums, convention and exhibition centers. The operating ambient temperature shall not be lower than 4°C and not higher than 52°C.

Product Description

FIS deluge valve adopts the Straight-through cone diaphragm seal, using the good self-sealing of the cone to open and close the valve. The pressure in the diaphragm chamber is released by electric, pneumatic or manual methods, the valve disc opens automatically so that the water can flow into the sprinkler system in one direction automatically and alarm at the same time. It can also form a variety of deluge alarm and firefighting systems with other components.

Note

The deluge valve with groove end connections may be ordered with or without control valves (water supply valve and upper service valve).

Deluge Valve
Model: FIS-DVL-FF/ FIS-DV-FF/
FIS-DVL-FG/FIS-DV-FG/
FIS-DVL-GG/FIS-DV-GG

Dimension

Figure 1 Outline dimensional drawing of deluge valve (Flange connection)

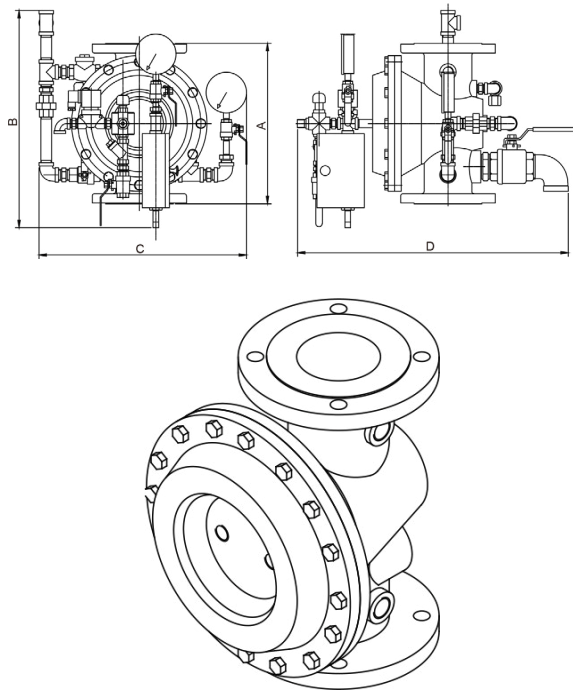

Type Description	
FIS-DVL-FF	FXF 250PSI
FIS-DV-FF	FXF 300PSI

Diameter (in/mm)	A (mm)	B (mm)	C (mm)	D (mm)
2/50	287±2	440±10	460±10	500±10
2.5/65	287±2	440±10	460±10	540±10
3/80	340(324)±2	450±10	490±10	570±10
4/100	390(350)±2	520±10	490±10	680±10
6/150	508(460)±2	570±10	570±10	800±10
8/200	584(570)±2	900±10	650±10	900±10

Figure 2 Outline dimensional drawing of deluge valve (Grooved * Flange connection)

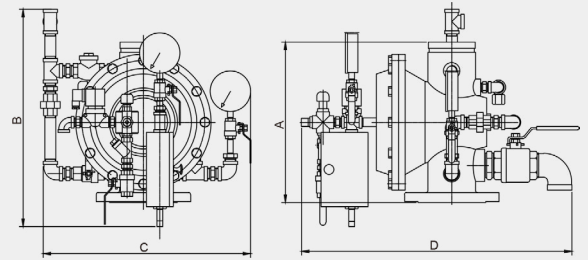

Type Description	
FIS-DVL-FG	FXG 250PSI
FIS-DV-FG	FXG 300PSI

Figure 3 Outline dimensional drawing of deluge valve (Grooved connection)

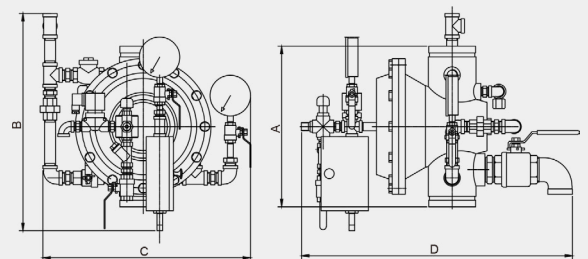

Type Description	
FIS-DVL-GG	GXG 250PSI
FIS-DV-GG	GXG 300PSI

Deluge Valve
Model: FIS-DVL-FF/ FIS-DV-FF/
FIS-DVL-FG/FIS-DV-FG/
FIS-DVL-GG/FIS-DV-GG

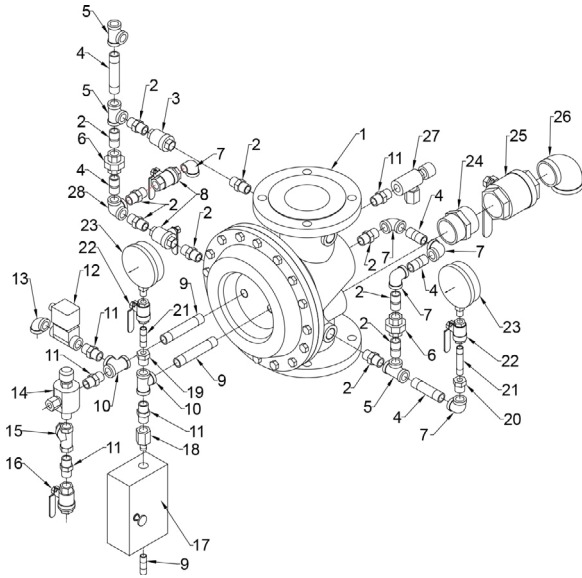

Structural characteristics

No	Name	QTY	Size	Material	Standard
1	Deluge valve	1	-	-	-
2	Butt joint	n	3/4"	DI/CF8/CF8M/ C95400/C95800	ASTM A536/ A351/B148
3	Check valve	1	3/4"	CF8/CF8M/ C95400/C95800	ASTM A351/ B148
4	Pipe fittings	n	3/4"	Gr.A/TP304/ C60800	ASTM A53/ A312/B111M
5	Tee joint	n	3/4"	DI/CF8/CF8M/ C95400/C95800	ASTM A536/ A351/B148
6	Union	2	3/4"	DI/CF8/CF8M/ C95400/C95800	ASTM A536/ A351/B148
7	90° Joint	n	3/4"	DI/CF8/CF8M/ C95400/C95800	ASTM A536/ A351/B148
8	Ball valve	2	3/4"	CF8/CF8M/ C95400/C95800	ASTM A351/ B148
9	Pipe fittings	n	1/2"	Gr.A/TP304/ C60800	ASTM A53/ A312/B111M
10	Tee joint	2	1/2"	DI/CF8/CF8M/ C95400/C95800	ASTM A536/ A351/B148
11	Butt joint	n	1/2"	DI/CF8/CF8M/ C95400/C95800	ASTM A536/ A351/B148
12	Solenoid valve	1	1/2"	-	-
13	90° Joint	n	1/2"	DI/CF8/CF8M/ C95400/C95800	ASTM A536/ A351/B148
14	Manual reset valve	1	1/2"	-	-
15	Y type filter	1	1/2"	CF8/CF8M/ C95400/C95800	ASTM A351/ B148
16	Ball valve	2	1/2"	CF8/CF8M/ C95400/C95800	ASTM A351/ B148
17	Emergency release valve bank	1	-	-	-
18	Release valve joint	1	1/2"	DI/CF8/CF8M/ C95400/C95800	ASTM A536/ A351/B148
19	Joint	1	1/2"- 1/4"	DI/CF8/CF8M/ C95400/C95800	ASTM A536/ A351/B148
20	Joint	1	3/4"- 1/4"	DI/CF8/CF8M/ C95400/C95800	ASTM A536/ A351/B148
21	Pipe fittings	n	1/4"	Gr.A/TP304/ C60800	ASTM A53/ A312/B111M
22	Ball valve	2	1/4"	CF8/CF8M/ C95400/C95800	ASTM A351/ B148
23	Pressure gauge	2	-	-	-
24	Butt joint	1	3/4"- 2"	DI/CF8/CF8M/ C95400/C95800	ASTM A536/ A351/B148
25	Ball valve	1	3/4"- 2"	CF8/CF8M/ C95400/C95800	ASTM A351/ B148
26	90° Joint	1	3/4"- 2"	DI/CF8/CF8M/ C95400/C95800	ASTM A536/ A351/B148
27	Drip valve	1	1/2"	-	-
28	Stereoscopic tee joint	1	3/4"	DI/CF8/CF8M/ C95400/C95800	ASTM A536/ A351/B148

Deluge Valve

**Model: FIS-DVL-FF/ FIS-DV-FF/
FIS-DVL-FG/FIS-DV-FG/
FIS-DVL-GG/FIS-DV-GG**

Installation

The deluge valve shall be installed in a room with a temperature greater than 4°C and less than 52°C with drainage facilities. It shall be installed close to the protection target for easy operation to reduce the length of the water distribution pipeline and improve the system response time.

The deluge valve can be installed horizontally or vertically. But the installation of the solenoid valve shall always keep the solenoid core in a vertical position. The set air pressure of the pneumatic actuator shall not be lower than the recommended minimum system air pressure (Table 1). Service clearance shall be reserved in four directions, with the distance to the ground of 1.2m, the distance from both sides to the wall not less than 0.5m, and the distance from the front to the wall not less than 1.2m.

The water supply control valve in front of the alarm valve and control valve behind the alarm valve shall be installed for convenience of repair and commissioning.

The valve body shall be installed as per the water flow direction indicated by arrows. Before installation, pipes shall be rinsed till the water becomes clear, in order to avoid the sealing performance of the valve from being affected by the deposited sediment or sewage.

Water motor alarm bell shall be installed on the outer walls of common aisle or near the duty room, and the steel pipe connecting the alarm bell to the deluge valve shall not be greater than 20m in length.

Table 1. Recommended minimum system air pressure

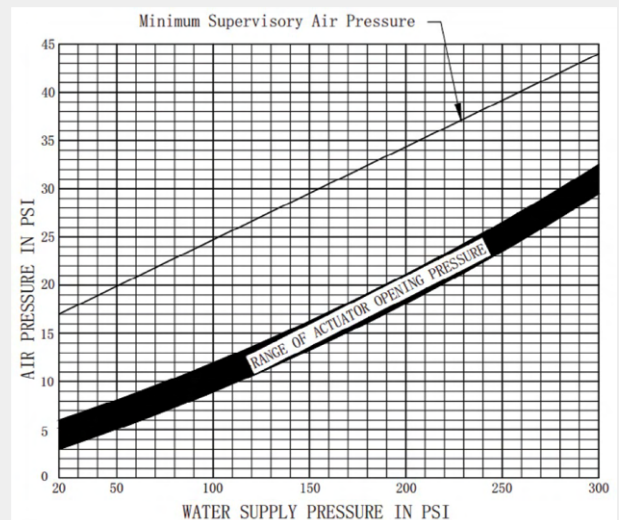

Reset Procedure

- Switch off the water supply control valve in front of the alarm valve and the ball valve on the water injection loop.
- Switch on the drain valve (switch off the auxiliary drain valve on the system, if any) to drain all the residual water in the system.
- Push the reset button of the drip valve at least twice; the water has been drained when the water flow is small or stops.
- Switch off all drain valves and the emergency manual release valve, and make sure the solenoid valve or pneumatic actuator is off and the ball valve on the alarm test loop is off.
- Switch on the ball valve on the water injection loop, and slowly press the reset valve reset button. In this process, it is normal for the reset valve to have water flowing out of the drain hole, and the water flow will stop when the pressure in the diaphragm chamber increases. Release the reset button when the indication values on the water supply pressure gauge and the diaphragm chamber pressure gauge are the same. Then completely switch on the water supply control valve in front of the alarm valve. The system enters the ready condition.
- Make sure the alarm system is open when the deluge valve group in a ready condition.

Deluge Valve
**Model: FIS-DVL-FF/
 FIS-DV-FF/FIS-DVL-FG/
 FIS-DV-FG/FIS-DVL-GG/
 FIS-DV-GG**

**Additional information that includes:
 Water Motor Gong, Pressure Switch and the trim**

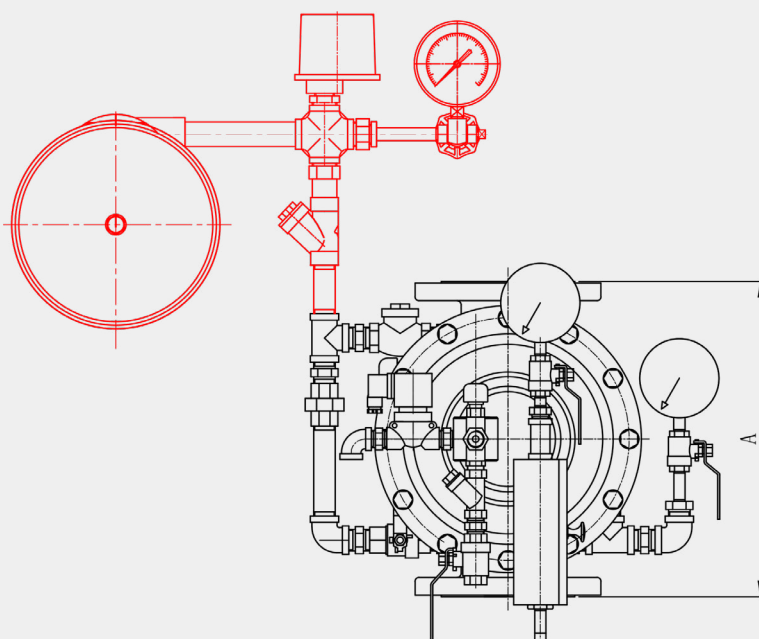
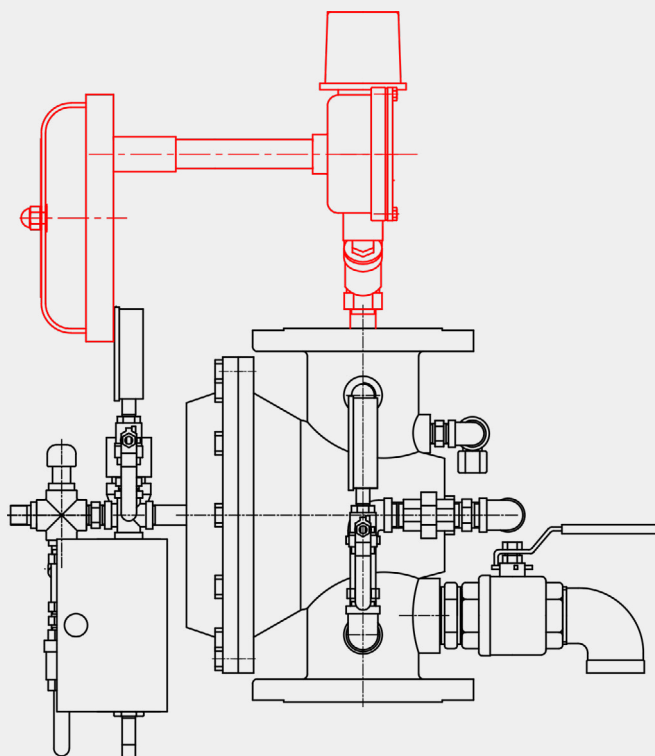

Technical Data	
Diameter (in/mm)	A (mm)
2/50	287 ± 2
2.5/65	287 ± 2
3/80	340 ± 2
4/100	390 ± 2
6/150	508 ± 2
8/200	584 ± 2

Deluge Valve

**Model: FIS-DVL-FF/ FIS-DV-FF/
FIS-DVL-FG/FIS-DV-FG/
FIS-DVL-GG/FIS-DV-GG**

Care and Maintenance

Alarm test, switch function test and other tests should be carried out regularly after the system is installed. After the test, open the drain valve of the alarm system, and close the valve after the water draining out from the valve group.

Alarm Test

The test is recommended to be conducted once a month (the frequency can be set based on factors such as fire rating and use environment). The test shall be conducted according to the following procedures:

- a: Switch on the ball valve on the alarm test loop when the valve bank is in the ready condition to make the water motor alarm bell or pressure switch actuate and alarm.
- b: Confirm that the alarm system is normal, switch off the ball valve on the alarm test loop to stop the alarm.

Manual Switch Function Test

The test is recommended to be conducted once every quarter (the frequency can be set based on factors such as fire resistance and use environment) in the warm climate. Before the test, drainage measures should be taken near the valve bank, and the alarm valve bank is in a ready condition. The test should be conducted according to the following procedures:

- a: Notify relevant personnel and departments.
- b: Switch off the control valve behind the alarm valve.
- c: Manually switch on the ball valve of the emergency release valve bank, and the readings on the pressure gauge in the diaphragm chamber decrease.
- d: Press the reset button of the drip valve, sufficient water flows out of the drain loop or the alarm system alarms, proving the successful actuation of the deluge alarm valve.
- e: Complete the reset following steps a through

f, and switch on the control valve behind the alarm valve. The manual switch function test is completed.

Remote Switch Function Test

The test is recommended to be conducted once every quarter (the frequency can be set based on factors such as fire resistance and use environment) in the warm climate. Before the test, drainage measures should be taken near the valve bank, and the alarm valve bank is in a ready condition. The test should be conducted according to the following procedures:

- a: Notify relevant personnel and departments.
- b: Switch off the control valve behind the alarm valve.
- c: Simulate a fire, and actuate a detector, so that the solenoid valve pneumatic actuator is switched on, and the readings on the pressure gauge in the diaphragm chamber drop.
- d: Press the reset button of the drip valve, sufficient water flows out of the drain loop or the alarm system alarms, proving the successful actuation of the deluge alarm valve.
- e: Complete the reset following steps a through f, and switch on the control valve behind the alarm valve. The remote switch function test is completed.

The deluge valve should be maintained and repaired regularly, and the maintenance and repair shall be conducted when the valve is disabled. The operating steps are shown as below:

- a: Switch off the water supply control valve in front of the alarm valve and the control valve behind the alarm valve, and switch off the ball valve on the water injection loop.
- b: Switch on the drain valve and emergency release valve of the deluge alarm valve. Maintenance and repair can be conducted at this time.



Gate 2, Aljada Logistics Area,
Behind Arada Project Management
Office, Near Airport Road,
Muweilah, 22436, Sharjah

rhinotek.ae

